

HP 41802A 1 M Ω Input Adapter

Operation Note

SERIAL NUMBERS

This manual applies directly to HP 41802As with serial number prefix 3103J. For additional important information about serial numbers, read "Serial Number" in Chapter 1.



HP Part No. 41802-90000
Printed in Japan February, 1999

2nd Edition

Certification

Hewlett-Packard Company certifies that this product met its published specifications at the time of shipment from the factory. Hewlett-Packard further certifies that its calibration measurements are traceable to the United States National Institute for Standards and Technology, to the extent allowed by the Institution's calibration facility, or to the calibration facilities of other International Standards Organization members.

Warranty and Assistance

All Hewlett-Packard products are warranted against defects in materials and workmanship. This warranty applies for one year from the date of delivery, or, in the case of certain major components listed in the operating manual, for the specified period. We will repair or replace products which prove to be defective during the warranty period provided they are returned to Hewlett-Packard. No other warranty is expressed or implied. We are not liable for consequential damages.

For any assistance, contact your nearest Hewlett-Packard Sales and Service Office. Addresses are provided at the back of this manual.

Limitation of Warranty

The foregoing warranty shall not apply to defects resulting from improper or adequate maintenance by Buyer, Buyer-supplied software or interfacing, unauthorized modification or misuse, operation outside of the environment specifications for the product, or improper site preparation or maintenance.

No other warranty is expressed or implied. HP specifically disclaims the implied warranties of merchantability and fitness for a particular purpose.

Caution

The HP 41802A is sensitive to electrostatic discharge (ESD). The followings must be adhered to when using the HP 41802A.

- Do *NOT* touch the center conductor of the BNC connector of the HP 41802A.
 - Do *NOT* touch the pin of the probe which is connected to the HP 41802A.
 - Eliminate ESD on your body.
 - Eliminate ESD on the work surface.
 - Do *NOT* introduce ESD into the DUT, while the HP 41802A and the probe is in use.
-

Contents

1. General Information	
Introduction	1-1
Compatible Equipment	1-2
Compatible Instruments	1-2
Compatible Probes	1-2
Serial Number	1-3
Specifications	1-4
Supplemental Performance Characteristics	1-5
2. Installation	
Introduction	2-1
Initial Inspection	2-2
Power Requirements	2-3
Mating Connectors	2-3
Environmental Requirements	2-4
3. Operation	
Introduction	3-1
Operating Precautions	3-2
Anti-static Precautions	3-2
Maximum Allowable Level	3-3
Discharging the Probe	3-3
Probe Power Plug	3-3
Preparation for Use	3-3
Operating Check Using a Network Analyzer	3-4
Using an HP 8751A or HP 3577A/B Network Analyzer	3-4
Equipment Required	3-4
Procedure	3-4
Using HP 8753A/B/C Network Analyzer	3-5
Equipment Required	3-5
Procedure	3-5
Operating Check Using a Spectrum Analyzer	3-6
Equipment Required	3-6
Procedure	3-6
Operating Check Using a Network/Spectrum Analyzer	3-7
Equipment Required	3-7
Procedure	3-7
Adjusting the Probe	3-8
Using a Network Analyzer	3-8
Equipment Required	3-8
Procedure	3-8
Using a Spectrum Analyzer	3-10
Equipment Required	3-10
Procedure	3-10
Typical Measurement Setups	3-11
Network Measurements	3-12

Using One HP 41802A	3-12
Using One HP 41802A with a Transmission/Reflection Test Set	3-13
Using Two HP 41802As	3-14
Spectrum Measurements	3-15
Using HP 41802A with instruments which have BNC connectors	3-16
4. Performance Test	
Introduction	4-1
Equipment Required	4-1
Calibration Cycle	4-2
Preparation	4-2
Gain Accuracy/Flatness Tests	4-3
Description	4-3
Specifications	4-3
Test Equipment	4-3
Procedure	4-3
Performance Test Record	4-6
Gain Accuracy/Flatness Tests	4-6
5. Adjustment	
Introduction	5-1
Equipment Required	5-1
Preparation	5-1
Gain Adjustment	5-2
Description	5-2
Equipment	5-2
Procedure	5-2
6. Replaceable Parts	
Replaceable Parts Lists	6-1
A. Manual Changes	
Introduction	A-1
Manual Changes	A-1

Figures

1-1. Serial Number Plate	1-3
1-2. Specifications	1-4
1-3. Supplemental Characteristics	1-5
2-1. Product Overview	2-2
2-2. Probe Power Requirements	2-3
3-1. Operating Check Setup Using HP 8751A or HP 3577A/B Network Analyzer	3-4
3-2. Operating Check Setup Using HP 8753A/B/C Network Analyzer	3-5
3-3. Operating Check Setup Using Spectrum Analyzer	3-6
3-4. Operating Check Setup Using Network/Spectrum Analyzer	3-7
3-5. Probe Adjustment Setup Using a Network Analyzer—1	3-8
3-6. Probe Adjustment Setup Using a Network Analyzer—2	3-9
3-7. Probe Adjustment Setup Using Spectrum Analyzer	3-10
3-8. Network Measurement Setup Example (Using One HP 41802A)	3-12
3-9. Network Measurement Setup Example (Using with a Transmission/Reflection Set)	3-13
3-10. Network Measurement Setup Example (Using Two HP 41802As)	3-14
3-11. Spectrum Measurement Setup Example	3-15
3-12. Measurement Setup Example (BNC input connector)	3-16
4-1. Test Setup 1	4-3
4-2. Test Setup 2	4-4
5-1. Adjustment Setup 1	5-2
5-2. Adjustment Setup 2	5-3
5-3. Adjustment Setup 3	5-4
6-1. Replaceable Parts (1 of 2)	6-2
6-2. Replaceable Parts (2 of 2)	6-4

Tables

2-1. Probe Power Requirements	2-3
3-1. Anti-static Products Available	3-2
4-1. Recommended Test Equipment	4-1
6-1. Component Manufactures	6-1
6-2. Replaceable Parts (2 of 2)	6-3
6-3. Replaceable Parts (2 of 2)	6-4
A-1. Manual Changes by Serial Number	A-1

General Information

Introduction

The HP 41802A 1 M Ω Input Adapter is used with high impedance passive probes for circuit signal analysis using network and spectrum analyzers.

This is an operation note for the HP 41802A, containing information on installation, operation, and service in the following chapters.

- Chapter 1, General Information

Provides the specifications and the information necessary for preparing the HP 41802A for use.

- Chapter 2, Installation

Provides the installation information, including initial inspection, power requirements, mating connectors, and environmental requirements.

- Chapter 3, Operation

Provides the information for preparation and typical measurement setups, including cautions on use.

- Chapter 4, Performance Test

Provides performance test procedures to ensure that the HP 41802A is within specifications.

- Chapter 5, Adjustment

Provides the adjustment procedure to bring it within specifications, if the HP 41802A failed the performance test or it has been repaired.

- Chapter 6, Replaceable Parts

Provides the replaceable parts information to service the HP 41802A.

Compatible Equipment

Compatible Instruments

Instruments compatible with the HP 41802A are network and spectrum analyzers which meet the following conditions.

Measurement frequency range includes 5 Hz to 100 MHz.

Input resistance is 50 Ω .

Probe power supplies are furnished.

The following HP network and spectrum analyzers are compatible with the HP 41802A.

Network Analyzers: HP 8751A, HP 8753A/B/C, HP 3577A/B

Spectrum Analyzers: HP 3585A/B, HP 8568B

Network/Spectrum Analyzer: HP 4195A

If the instrument does not have a probe power supply, use a separate power supply which meets the requirements described in “Power Requirements” in Chapter 2.

Compatible Probes

Compatible probes with the HP 41802A are high impedance passive probes which meet the following conditions.

Input resistance is 1 M Ω .

Compensates oscilloscope input capacitance includes 12 pF.

The following HP Oscilloscope Probes are compatible with the HP 41802A.

HP 10432A, HP 10433A, HP 10435A, HP 10440A

HP 10017A, HP 10018A, HP 10080A, HP 10081A

Refer to “Adjusting the Probe” in Chapter 3 how to adjust the probe which is connected to a network analyzer or a spectrum analyzer.

Serial Number

Hewlett-Packard uses a two-part, nine character serial number which is stamped on the serial number plate (see Figure 1-1) attached to the instrument's rear panel. The first four digits and a letter are the prefix, and the last five digits are the suffix of the serial number. The letter in the serial number identifies the country where the instrument was manufactured. The prefix is same for all identical instruments; it changes only when a change is made to the instrument. The suffix, however, is assigned sequentially and is different for each instrument. This operation note applies to instruments with the serial number prefixes listed under SERIAL NUMBERS on the title page.

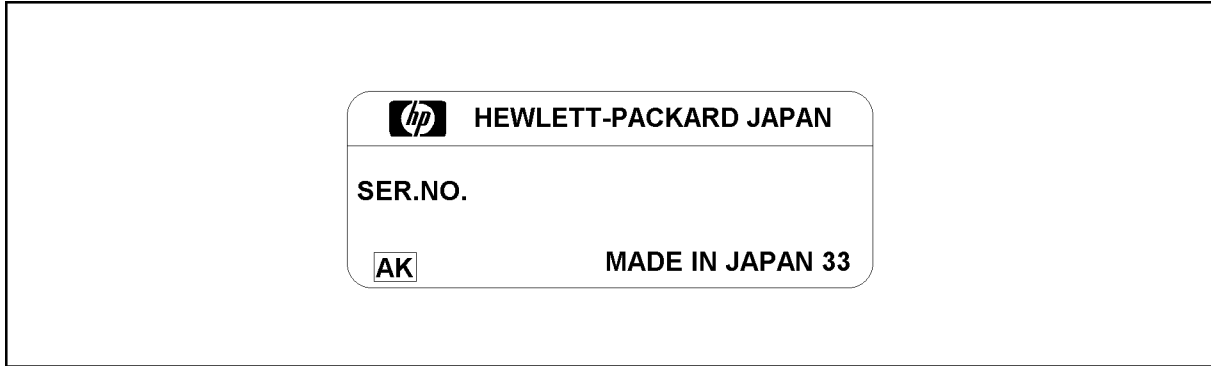

Figure 1-1. Serial Number Plate

Units manufactured after this operation note was printed may have a serial number prefix that is not listed on the title page. An unlisted serial number prefix indicates that the instrument may be different from those described in this operation note. Operation notes for new instruments may be accompanied by a yellow Manual Supplement page or have a different manual part number. This supplement contains “Change Information” explaining how to adapt this operation note to the newer instruments.

In addition to change information, the supplement may contain information for correcting errors (Errata) in the previous operation notes. To keep this manual as current and accurate as possible, Hewlett-Packard recommends that you periodically request the latest Manual Changes supplements. The supplement for this operation note is identified by the Print Date and HP Part No., both of which appear on the operation note's title page.

For information concerning the serial number prefix not listed on the title page or in the Manual Change supplements, contact your nearest Hewlett-Packard office.

Specifications

Figure 1-2 lists the specifications for the HP 41802A. The specifications are performance standards or limits. The HP 41802A meets all of the specifications listed in Figure 1-2, when it is shipped from the factory.

- Specifications describe the instrument's warranted performance over the temperature range of 23 ± 5 °C (except where noted).
- Supplemental characteristics are intended to provide information useful in applying the instrument by giving non-warranted performance parameters. These are denoted as "typical," "nominal," or "approximate."

Frequency Range:

5 Hz to 100 MHz

Accuracy¹: (Input Level = -3 dBm, at 1 MHz)

0 dB \pm 2 dB

0 dB \pm 0.5 dB (typical)

Flatness¹ (relative to 1 MHz): (Input Level = -3 dBm)

\pm 2.8 dB

\pm 1 dB (typical, at 50 Hz to 100 MHz)

+1/-2 dB (typical, at 5 Hz to 50 Hz)

Damage Level:

>2 Vrms, >50 Vdc

Power:

+15 V, 45 mA nominal

-12.6 V, 40 mA nominal

Operating Temperature:

0 to 55 °C

Operating Relative Humidity:

\leq 95% at 40 °C (Non-condensing)

Dimension:

approximately 30(H) x 42(W) x 116(D) mm (excluding the cable)

Weight:

approximately 250 g

¹ The performance is specified when the HP 41802A is terminated with an HP 10100C 50 Ω Feedthrough Termination.

Figure 1-2. Specifications

Supplemental Performance Characteristics

Figure 1-3 lists the supplemental performance characteristics for the HP 41802A. Supplemental performance characteristics are not specifications, but are typical characteristics included as additional information for the operator. Supplemental performance characteristics are not guaranteed.

- Supplemental Characteristics describe the instrument's performance over the temperature range of 23 ± 5 °C (except where noted).

1 dB Gain Compression¹ : (Input Level = +3 dBm)

0.32 Vrms (at 1 MHz)

Input Resistance:

1 M Ω

Input Capacitance:

12 pF

¹ The following performance is specified when the HP 41802A is terminated with an HP 10100C 50 Ω Feedthrough Termination.

Figure 1-3. Supplemental Characteristics

Installation

Introduction

This chapter contains the following information.

- Initial inspection
- Power Requirements
- Mating connector
- Environmental requirements

Initial Inspection

Caution



Electrostatic Discharge (ESD) can damage the HP 41802A's highly sensitive input amplifier. Do *NOT* touch the center conductor of the BNC connector of the HP 41802A.

The HP 41802A meets all of the specifications listed in Figure 1-2. Upon receipt, inspect the shipping container for damage. If the shipping container or the cushioning has been damaged, keep the container and packing material until the contents have been checked for completeness and the HP 41802A has been mechanically and electrically checked out. Figure 2-1 shows the product overview of the HP 41802A. The procedures for checking the general electrical operation are given in Chapter 4.

If anything is damaged (scratches, dents, broken connectors, etc.), or if performance does not meet the specified performance test limits, notify the nearest HP sales office (see the list at the back of this operation note). The HP sales office will immediately arrange for repair or replacement without waiting for a claim settlement.

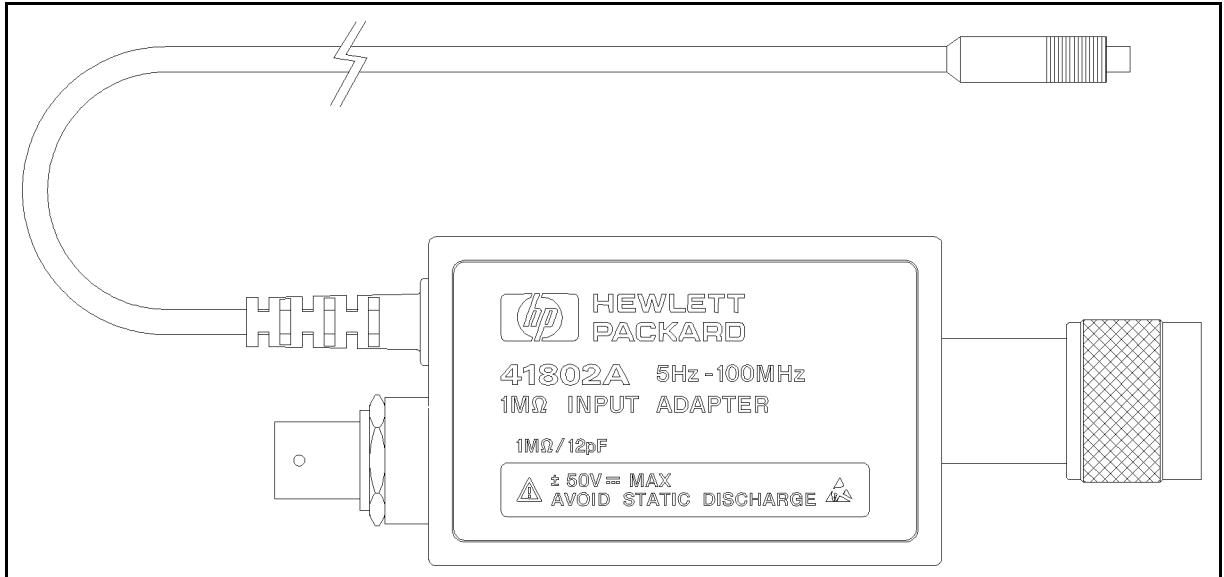
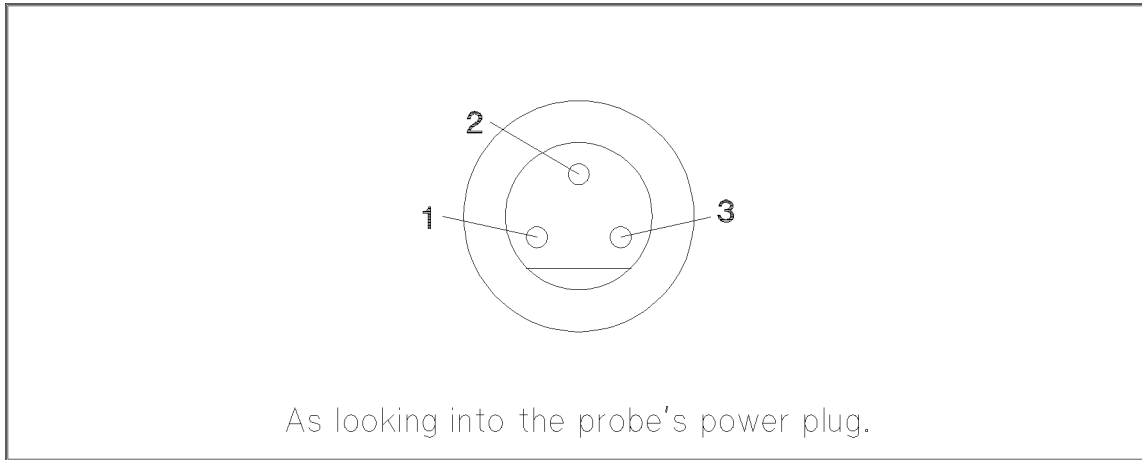

Figure 2-1. Product Overview

Power Requirements

Power for the HP 41802A is supplied by the compatible instruments described in “Compatible Instruments” in Chapter 1 by connecting the HP 41802A’s power plug to the probe power jack on the instrument. If the instrument used with the HP 41802A does not have a probe power supply, use a separate power supply which meets the requirements listed in Table 2-1. The HP 1122A and HP 11899A Probe Power Supply meets these requirements and it accepts the HP 41802A’s probe power plug directly.



A8002002

Figure 2-2. Probe Power Requirements

Table 2-1. Probe Power Requirements

Pin	Voltage	Current
1	-12.6 V \pm 10%	40 mA
2	Ground	
3	+15 V \pm 6%	45 mA

Mating Connectors

The output connector of the HP 41802A is a 50 Ω N-type male connector.

Note Keep the N-type output connector clean.



Caution Trying to mate this 50 Ω N-type connector to a 75 Ω N-type connector will result in damage to both connectors.



Environmental Requirements

The HP 41802A may be stored or shipped under the following environmental conditions.

Temperature: $-40\text{ }^{\circ}\text{C}$ to $+70\text{ }^{\circ}\text{C}$

Humidity: $\leq 95\%$ at $40\text{ }^{\circ}\text{C}$ (Non-condensing)

The unit must be protected from temperature extremes which can cause condensation.

Operation

Introduction

This chapter provides the following information.

- Operating precautions
- Preparation for use
- Typical measurement setups

Operating Precautions

This paragraph describes precautions for using the HP 41802A to prevent from damage on the HP 41802A and your device under test (DUT).

Anti-static Precautions

Caution



The HP 41802A is sensitive to electrostatic discharge (ESD). The following must be adhered to when using the HP 41802A.

- Do *NOT* touch the center conductor of the BNC connector of the HP 41802A.
- Do *NOT* touch the pin of the probe which is connected to the HP 41802A.

The probe input circuit is highly susceptible to damage by ESD introduced through the input connector.

- Eliminate ESD on your body.

Wear a snug-fitting ground strap that is connected to earth ground through a high resistance. Table 3-1 lists the available anti-static products.

- Eliminate ESD on the work surface.

A grounded anti-static bench mat is recommended. Optional floor mats provide an extra measure of protection, especially in areas with floor carpet. Do *NOT* use the HP 41802A on a carpeted work surface.

- Do *NOT* introduce ESD into the DUT while the probe is in use.

If an unprotected person touches a part of the DUT, a static surge could damage the DUT as well as the probe.

Table 3-1. Anti-static Products Available

Description	HP Part Number
Liquid Anti-static Agent	8550-3397
Static Control Table Mat with Ground Cord	9300-0797
Small Wrist Strap with Ground Cord	9300-1099
Medium Wrist Strap with Ground Cord	9300-1117
Large Wrist Strap with Ground Cord	9300-1242

Maximum Allowable Level

Caution Maximum allowable level (ac+dc) to the probe is ± 50 V.



Discharging the Probe

Caution Measuring a node having a dc voltage potential charges the blocking capacitors inside the HP 41802A. Ground the probe pin after measuring such nodes to discharge probe capacitor. Failure to do this could result in damage to sensitive circuits in the DUT, especially if it is an active device.



Probe Power Plug

Note Connect the probe power plug, before connecting the N-type connector.



Preparation for Use

This paragraph provides the HP 41802A operating check procedure and the probe adjustment procedure.

The HP 41802A operating check procedure checks the adapter gain using a network analyzer, a spectrum analyzer, or a network/spectrum analyzer. These operating check procedures are only intended to ensure that the HP 41802A is functional. If the HP 41802A fails this check, it should be repaired. To verify that the HP 41802A meets its specifications, perform the performance test described in Chapter 4.

The probe adjustment procedure is for frequency compensation. For the best measurement results, always adjust the probe.

Operating Check Using a Network Analyzer

Using an HP 8751A or HP 3577A/B Network Analyzer

This section provides the HP 41802A operating check procedure using the HP 8751A or the HP 3577A/B network analyzer.

Equipment Required.

Network Analyzer: HP 8751A or HP 3577A/B
BNC(m)-BNC(m) Cable, 30 cm: PN 8120-1838
Adapters: as necessary

Procedure.

1. Connect the equipment as shown in Figure 3-1. Note that the probe power plug must be connected before connecting the HP 41802A's N-type connector.

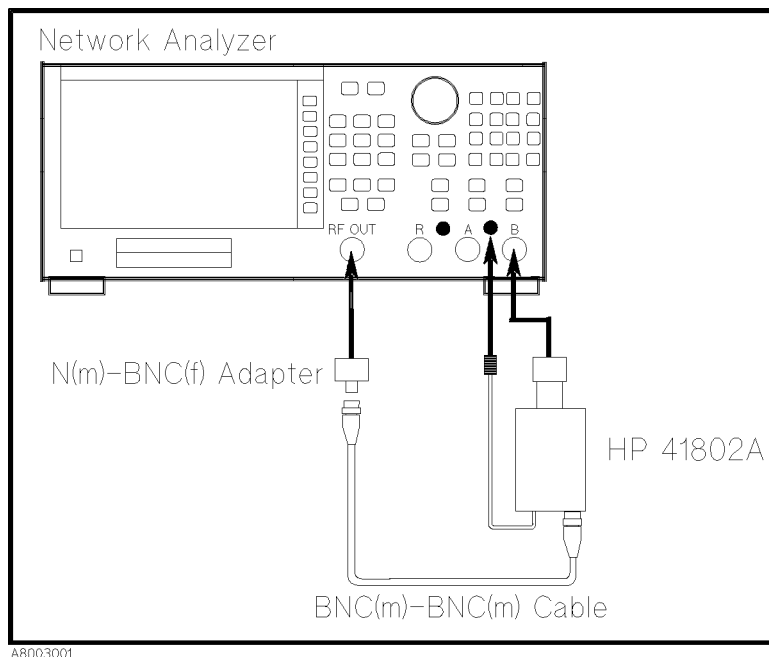

Figure 3-1. Operating Check Setup Using HP 8751A or HP 3577A/B Network Analyzer

2. Set the network analyzer as follows:

Measurement Mode: B(, A, or R) (absolute amplitude measurement)
Center Frequency: 1 MHz
Frequency Span: 0 Hz
Output Level: -10 dBm

3. Confirm that the signal level is '-4 dB ± 5 dB.'

Note

If the signal level is lower than the limit, confirm that the power trip function is set to OFF.



Using HP 8753A/B/C Network Analyzer

This section provides the HP 41802A operating check procedure using the HP 8753A/B/C network analyzer.

Equipment Required.

Network Analyzer:	HP 8753A/B/C
50 Ω Feedthrough:	HP 10100C
BNC(m)-BNC(m) Cable, 30 cm:	PN 8120-1838
Adapters:	as necessary

Procedure.

1. Connect the equipment as shown in Figure 3-2. Note that the probe power plug must be connected before connecting the HP 41802A's N-type connector.

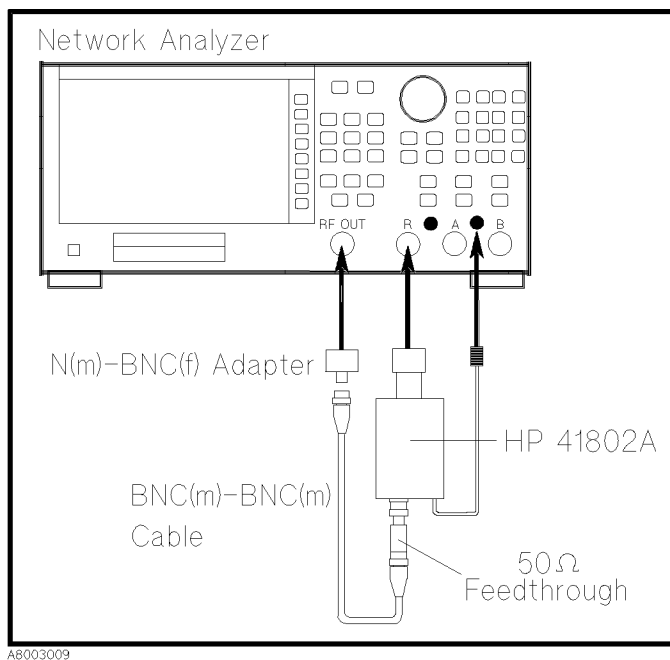

Figure 3-2. Operating Check Setup Using HP 8753A/B/C Network Analyzer

2. Set the network analyzer as follows:

Measurement Mode:	R (absolute amplitude measurement)
Center Frequency:	1 MHz
Frequency Span:	0 Hz
Output Level:	-5 dBm

3. Confirm that the signal level is '-5 dB \pm 5 dB.'

Note

If the signal level is lower than the limit, confirm that the power trip function is set to OFF.



Operating Check Using a Spectrum Analyzer

This section provides the HP 41802A operating check procedure using a spectrum analyzer.

Equipment Required

Spectrum Analyzer:	Any Compatible Spectrum Analyzer
BNC(m)-BNC(m) Cable, 61 cm:	PN 8120-1839
50 Ω Feedthrough:	HP 10100C
Adapters:	as necessary

Procedure

1. Connect the equipment as shown in Figure 3-3. Note that the probe power plug must be connected before the HP 41802A's N-type connector.

Note



If the spectrum analyzer has a tracking generator output, use the tracking generator output connector instead of the calibration output connector. Then set the output level to ≤ -10 dBm.

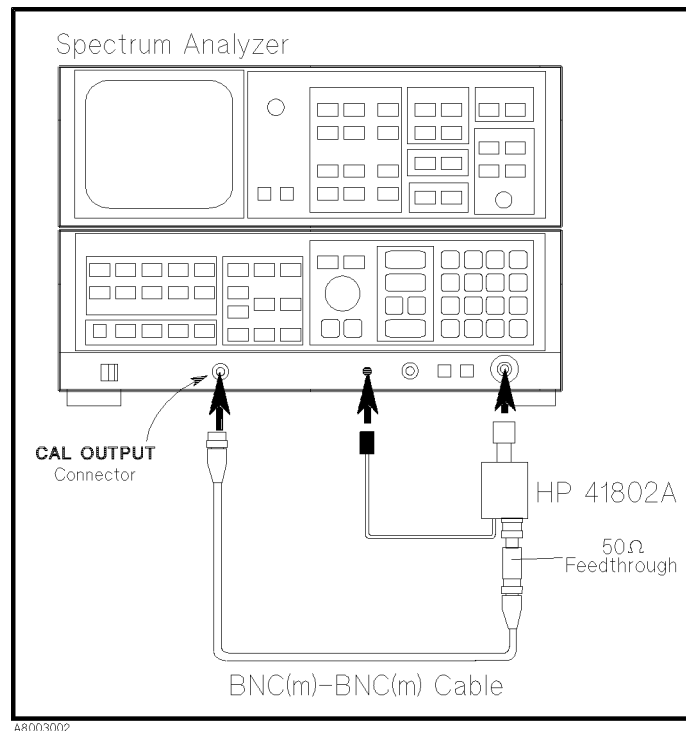

Figure 3-3. Operating Check Setup Using Spectrum Analyzer

2. Setup the spectrum analyzer as follows:

Center Frequency:	Same as Calibration Output frequency.
Frequency Span:	0 Hz.
Attenuation:	40 dB.

3. Confirm that the signal level is 'calibration output level ± 5 dB.'

Operating Check Using a Network/Spectrum Analyzer

This section provides the HP 41802A operating check procedure using the HP 4195A network/spectrum analyzer.

Equipment Required

Network/Spectrum Analyzer: HP 4195A
BNC(m)-BNC(m) Cable, 30 cm: PN 8120-1838
Adapters: as necessary

Procedure

1. Connect the equipment as shown in Figure 3-4. Note that the probe power plug must be connected before the HP 41802A's N-type connector.

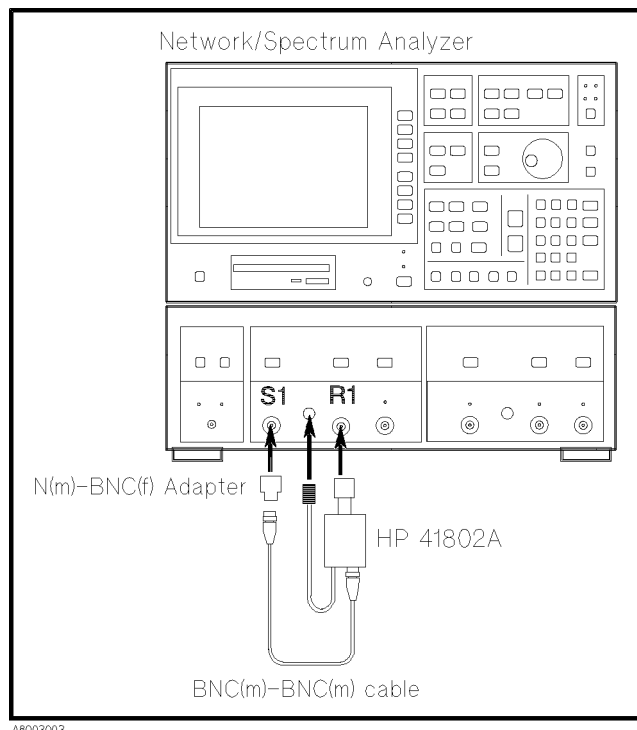

Figure 3-4. Operating Check Setup Using Network/Spectrum Analyzer

2. Set up the Network/Spectrum analyzer as follows:

Configuration: Spectrum
Center Frequency: 1 MHz
Frequency Span: 0 Hz
Port Select: Source Channel 1 on
Amplitude (S1): -26 dBm
Ref Attenuator (R1): 10 dB

3. Confirm that the signal level is '-20 dB \pm 5 dB.'

Adjusting the Probe

Using a Network Analyzer

This section provides the probe adjustment procedure using a network analyzer.

Equipment Required.

Network Analyzer:	Any Compatible Network Analyzer
Power Splitter:	HP 11667A
N(m)-N(m) Adapter:	PN 1250-0778
N(m)-BNC(m) Adapter:	PN 1250-0780, 2 ea.
50 Ω Feedthrough:	HP 10100C
N(m)-N(m) Cable:	HP 11500B
BNC(m)-BNC(m) Cable:	PN 8120-1838

Procedure.

1. Connect the equipment as shown in Figure 3-5.

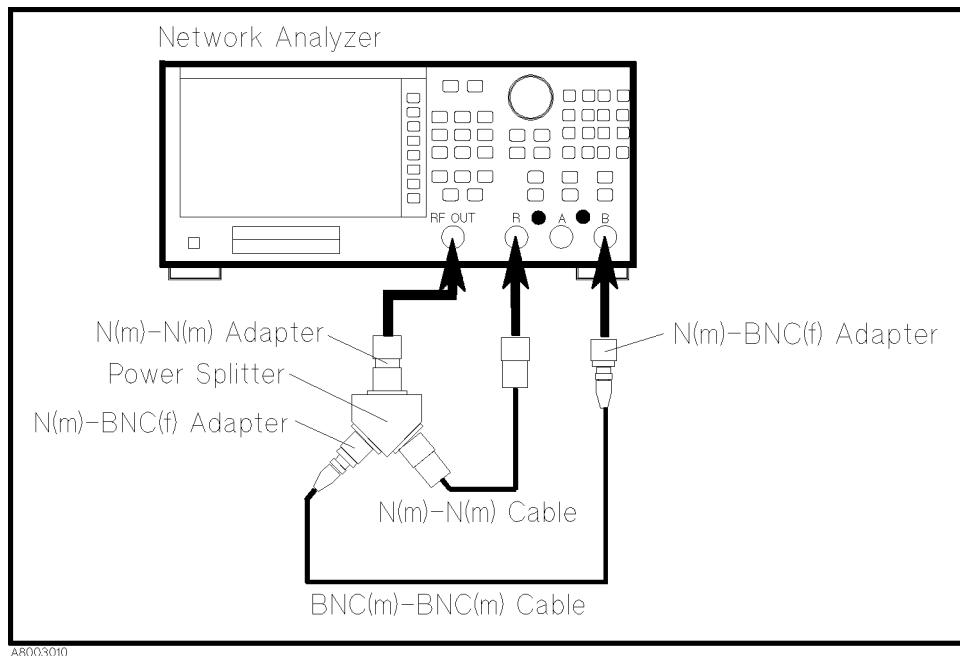

Figure 3-5. Probe Adjustment Setup Using a Network Analyzer—1

2. Setup the network analyzer as follows:

Measurement Mode:	B/R
Start Frequency:	5 Hz
Stop Frequency:	100 MHz
Sweep Type:	Log Frequency
Source Power:	-5 dBm
IF BW:	2 Hz

3. Perform a response calibration.

4. Change the connection as shown in Figure 3-6. Connect the ground lead firmly to provide good electrical bond.

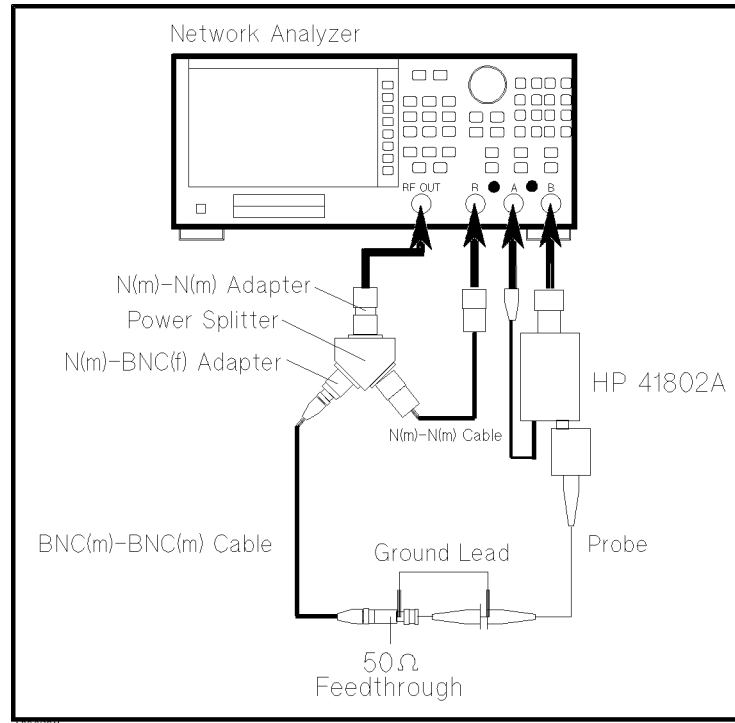

Figure 3-6. Probe Adjustment Setup Using a Network Analyzer—2

5. Touch the center pin of the feedthrough with the probe tip.
6. Adjust the trimmer component (through opening in probe assembly cover) until the trace is as close to -20 dB as possible.

Note



Only the mid-frequency range is adjustable. (The low frequency and high frequency range are not adjustable.) The adjustable range depends on the probe you use.

Using a Spectrum Analyzer

This section provides the probe adjustment procedure using a spectrum analyzer.

Equipment Required.

Spectrum Analyzer:	Any Compatible Spectrum Analyzer
50 Ω Feedthrough:	HP 10100C
Adapters:	as necessary

Procedure.

1. Connect the equipment as shown in Figure 3-7. Note that the probe power plug must be connected before the HP 41802A's N-type connector. Connect the ground lead firmly to provide good electrical bond.

Note



If the spectrum analyzer has a tracking generator output, use the tracking generator output connector instead of the calibration output connector. Then set the output level to ≤ -10 dBm.

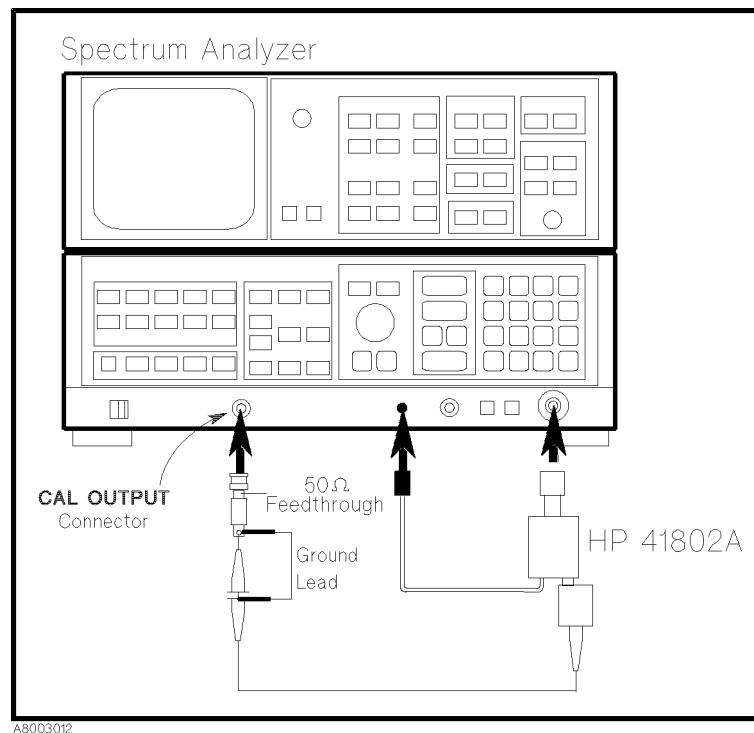

Figure 3-7. Probe Adjustment Setup Using Spectrum Analyzer

2. Setup the spectrum analyzer as follows:

Center Frequency:	Same as Calibration Output frequency.
Frequency Span:	50 kHz.
Attenuation:	10 dB.

3. Touch the center conductor of the feedthrough with the probe tip.
4. Adjust the trimmer component (through opening in probe assembly cover) until the peak signal level is as close to 'calibration output level - 20 dB' as possible.

Typical Measurement Setups

This paragraph provides typical measurement setups using the HP 41802A. The following setups are described.

- Network Measurement Setups
 - Using one HP 41802A
 - Using one HP 41802A with a transmission/reflection test set
 - Using two HP 41802As
- Spectrum Measurement Setups
- Using the HP 41802A with instruments which have BNC connectors

Caution



Electrostatic discharge (ESD) can damage the HP 41802A's highly sensitive input amplifier.

Do *NOT* touch the center conductor of the BNC connector of the HP 41802A.

Do *NOT* touch the pin of the probe which is connected to the HP 41802A.

Do not apply a ac+dc level which exceeds ± 50 V to the probe.

Do not mate the output connector of the probe assembly (50 Ω type-N connector) to 75 Ω type-N connectors or damage may results.

Note



Connect the probe power plug before connecting the N-type connector.

Network Measurements

Using One HP 41802A

Figure 3-8 shows a typical measurement setup for the network measurements. Place the probe tip as close to the input of the device under test, and perform a normalize (through) calibration to compensate the frequency response error.

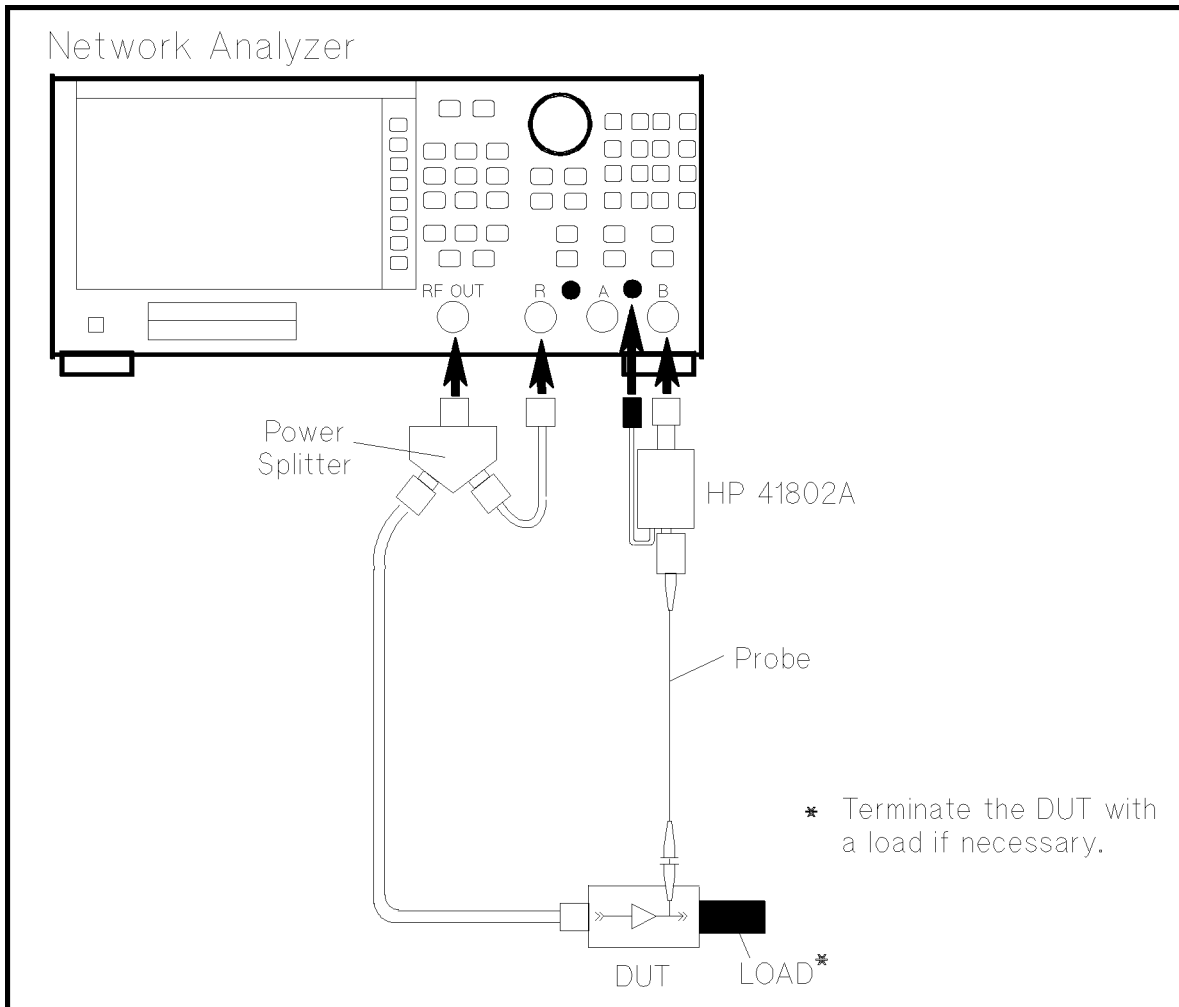
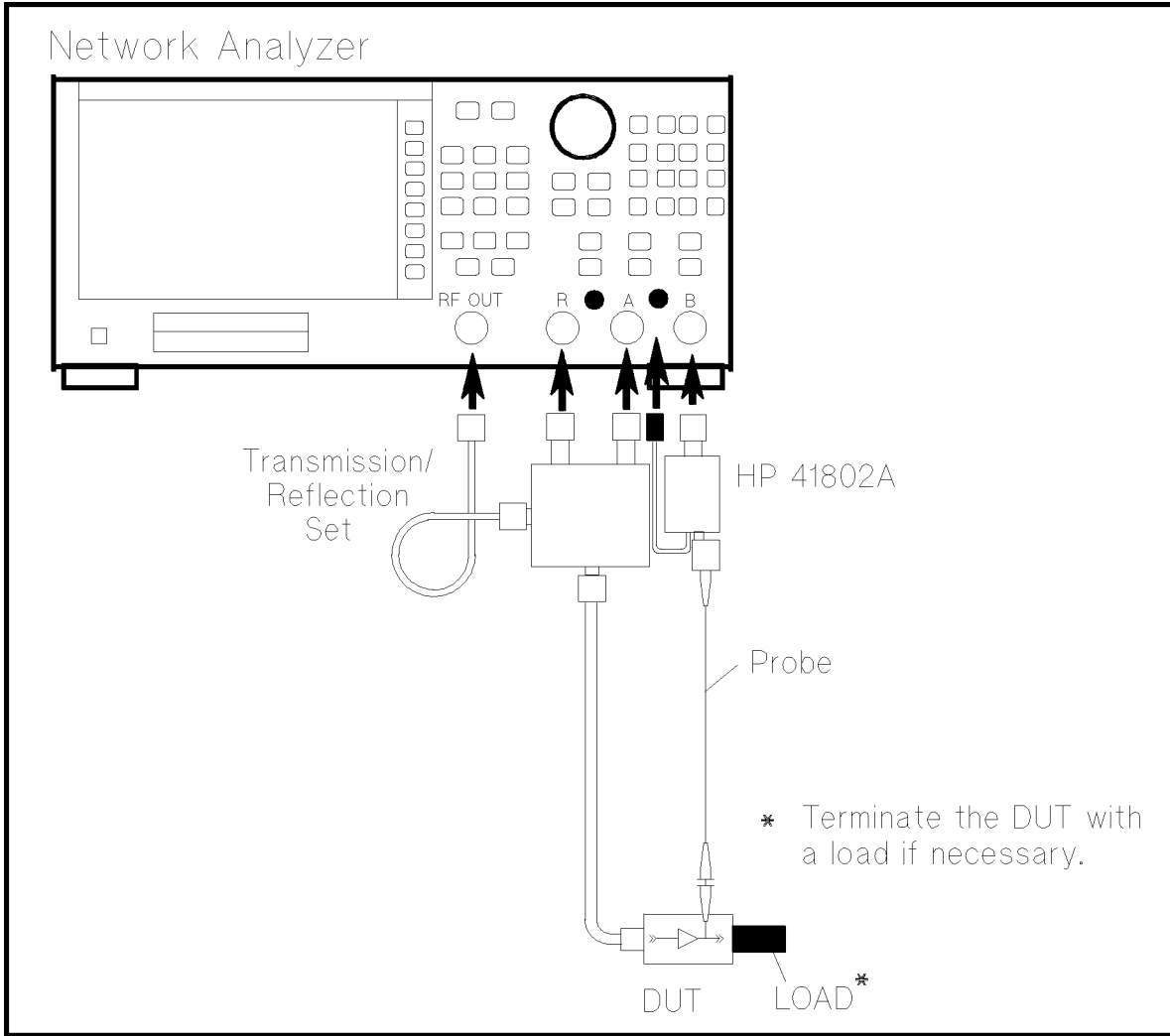

Figure 3-8. Network Measurement Setup Example (Using One HP 41802A)

Using One HP 41802A with a Transmission/Reflection Test Set

Figure 3-9 shows typical measurement setup for the network measurements using with a transmission/reflection test set. Place the probe tip as close to the input of the device under test, and perform a normalize (through) calibration to compensate the frequency response error.



A8003005

Figure 3-9.
Network Measurement Setup Example (Using with a Transmission/Reflection Set)

Using Two HP 41802As

Figure 3-10 shows typical measurement setup for network measurements using two probes. Place the probe tip as close as possible to the input of the device under test, and perform a normalize (through) calibration to compensate the frequency response error.

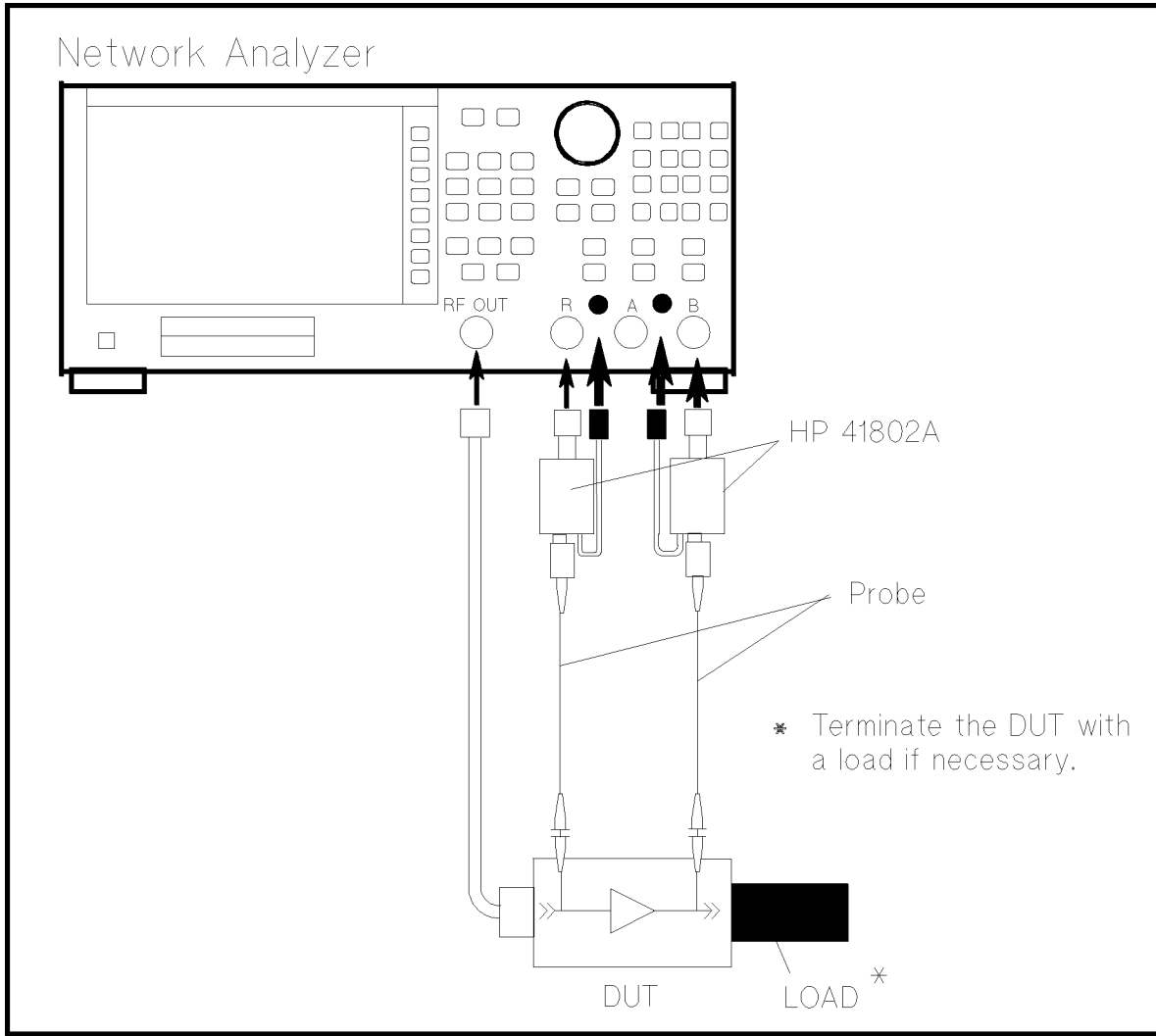

A8003006

Figure 3-10. Network Measurement Setup Example (Using Two HP 41802As)

Note

Use Input R and Input B to reduce cross talk.



If you want to set two HP 41802As side by side:

Set the HP 41802As vertically in the same direction.

Set the HP 41802As parallel and do not let them touch each other.

Spectrum Measurements

Figure 3-11 shows typical measurement setup using a spectrum analyzer.

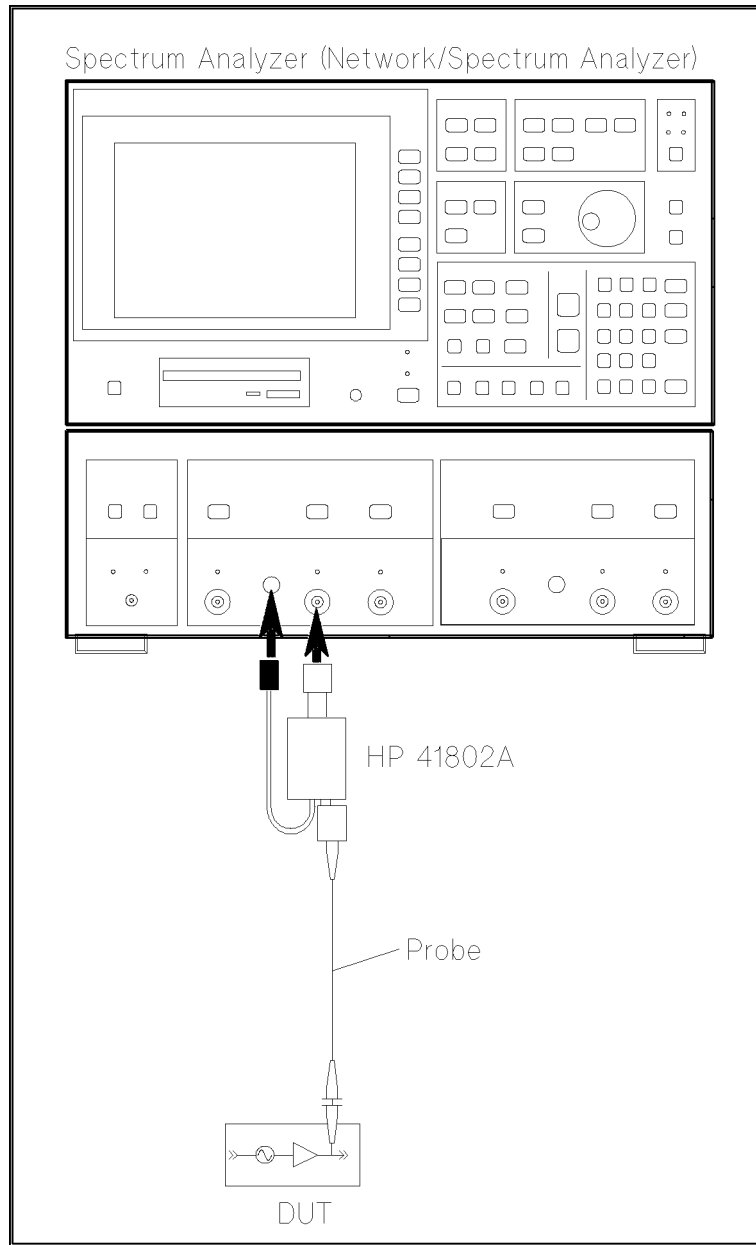

Figure 3-11. Spectrum Measurement Setup Example

Using HP 41802A with instruments which have BNC connectors

Figure 3-12 shows typical measurement setup using a instrument which has a BNC input connector. A BNC(m) cable and N(f)-BNC(m) adapter are recommended to use for connecting the HP 41802A to the instrument. Do not use an inflexible adapter such as a BNC(m)-N(f) adapter instead of the cable and N(f)-BNC(f) adapter, otherwise the overweight caused by the HP 41802A may damage the instrument's connector.

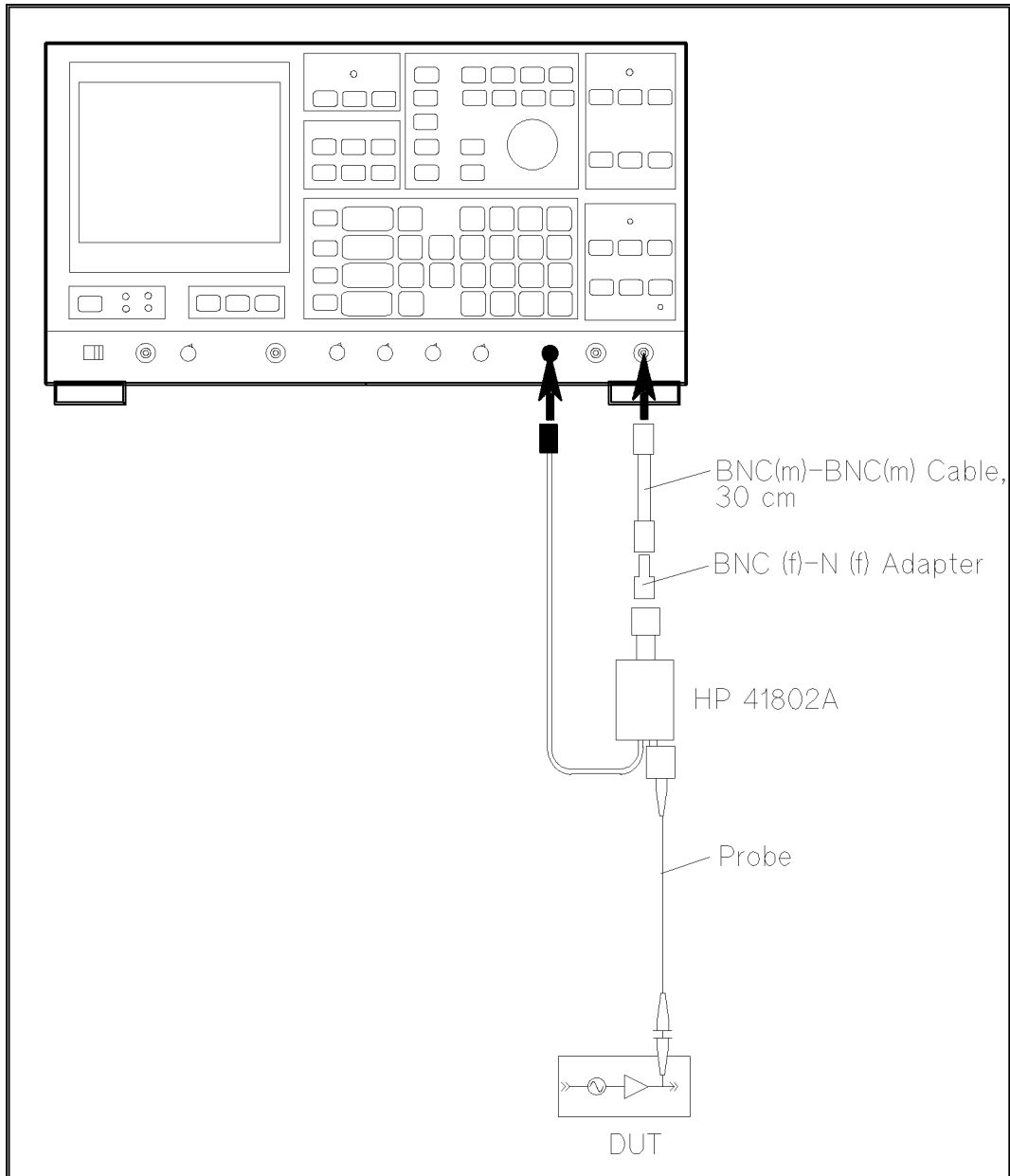

Figure 3-12. Measurement Setup Example (BNC input connector)

Performance Test

Introduction

This chapter provides performance test procedure to ensure that the HP 41802A meets the specifications listed in Figure 1-2. The performance test can be performed without accessing the interior of the HP 41802A.

The test results should be recorded into the Performance Test Record which is located at the end of this chapter.

Equipment Required

The equipment required for performance testing is listed in Table 4-1. Substitutions can be made if the substitution equipment meets or exceeds the specifications listed in the Requirements column.

Table 4-1. Recommended Test Equipment

Equipment	Critical Specifications	Recommended Model	Qty.
Network Analyzer	No substitute	HP 8751A or HP 4195A	1
Power Splitter	Frequency: 10 Hz to 100 MHz, Equivalent Output SWR: ≤ 1.1 (@ ≤ 100 MHz)	HP 11667A	1
Adapter	50 Ω , N(m)-N(m)	PN 1250-0778	1
	50 Ω , N(m)-BNC(f)	PN 1250-0780	2
Attenuator Pad	ATT 10 dB, Impedance 50 Ω , N(m)-N(f)	HP 8491A Opt. 010	1
	ATT 20 dB, SWR: ≤ 1.2 , Impedance 50 Ω , N(m)-N(f)	HP 8491A Opt. 020	1
Cables	50 Ω , N(m)-N(m)	HP 11500B	1
	50 Ω , BNC(m)-BNC(m), 30cm	PN 8120-1838	1
Coaxial Load	50 Ω Feed through, BNC(m)-BNC(f), VSWR: ≤ 1.1 (@ ≤ 100 MHz)	HP 10100C	1

Calibration Cycle

The HP 41802A requires periodic performance verification. The HP 41802A should be checked out using the performance test at least once a year or more depending on its frequency of use.

Preparation

This paragraph provides the information which you should know and the steps that you should perform before starting the performance test.

1. Allow the HP 41802A and the test equipment to warm up and stabilize for at least 30 minutes before you execute any of the performance tests.
2. Perform all performance tests in an ambient temperature of $23\text{ }^{\circ}\text{C} \pm 5\text{ }^{\circ}\text{C}$.

Gain Accuracy/Flatness Tests

Description

This test checks the gain at 1 MHz, and the flatness (relative to 1 MHz).

Specifications

Gain Accuracy: $0 \text{ dB} \pm 2 \text{ dB}$ at 1 MHz
Flatness: $\pm 2.8 \text{ dB}$ relative to 1 MHz

Test Equipment

Network Analyzer:	HP 8751A
Power Splitter:	HP 11667A
10 dB Attenuator Pad:	HP 8491A Opt. 010
20 dB Attenuator Pad:	HP 8491A Opt. 020
N(m)-N(m) Adapter:	PN 1250-0778
N(m)-BNC(f) Adapter:	PN 1250-0780, 2 ea.
50 Ω Feed through:	HP 10100C
N(m)-N(m) Cable:	HP 11500B
BNC(m)-BNC(m) Cable:	PN 8120-1838

Procedure

1. Connect the equipment as shown in Figure 4-1.

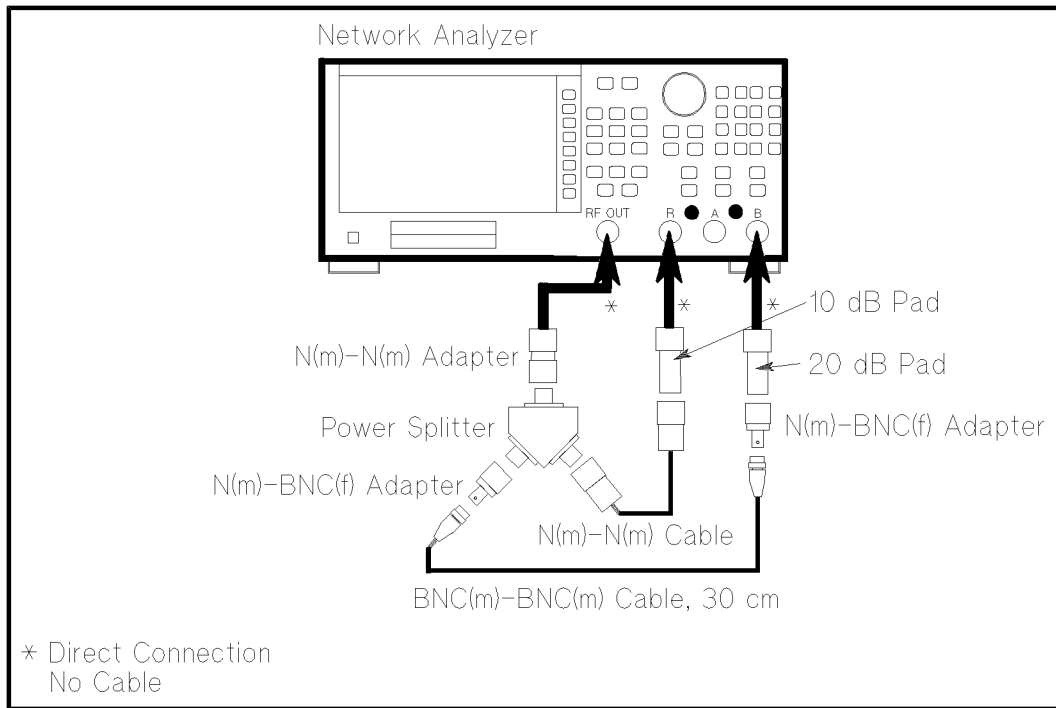

Figure 4-1. Test Setup 1

2. Setup the HP 8751A as follows:

Control Settings	Key Strokes
Preset	PRESET
Start Freq. = 10 Hz	START 1 0 x1
Stop Freq. = 100 MHz	STOP 1 0 0 M/μ
Meas. Config: B/R	MEAS B/R
Number of Points: 8	MENU NUMBER of POINTS 8 x1
Sweep Type: LOG FREQ	MENU SWEEP TYPE MENU LOG FREQ
IF BW = 2 Hz	AVG IF BW 2 x1
Source Power = +3 dBm	MENU POWER 3 x1
Marker: Discrete	MKR MARKER MODE MENU MARKERS: DISCRETE

3. Perform the following key strokes to do a response calibration.

CAL **CALIBRATE MENU** **RESPONSE** **THRU** **DONE:RESPONSE**

4. Change the connection as shown in Figure 4-2

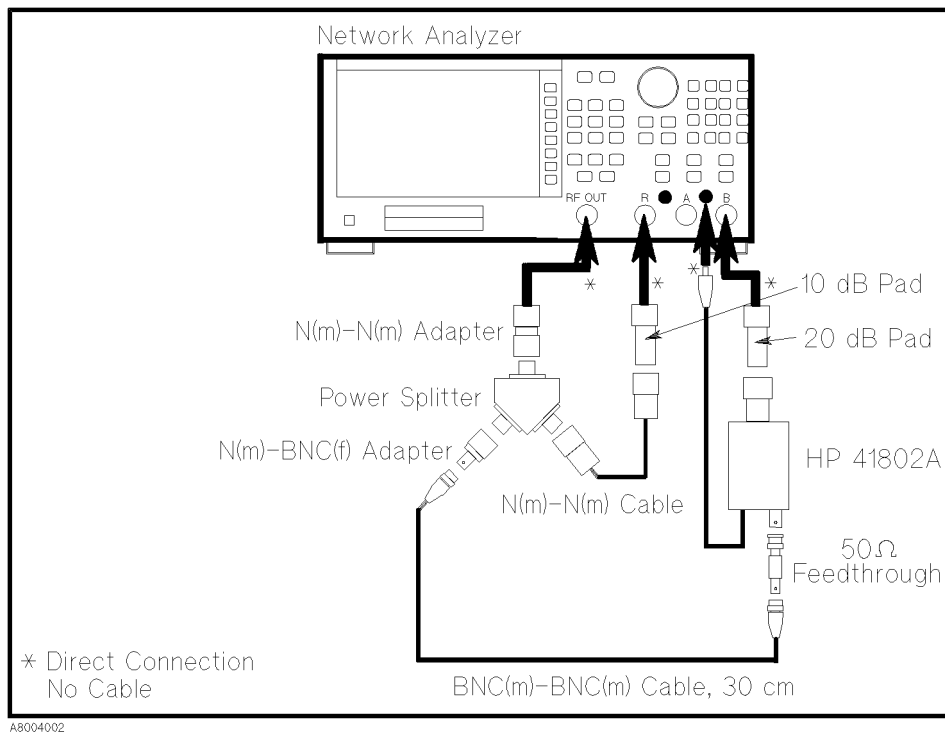

Figure 4-2. Test Setup 2

5. Perform the following key strokes for a single measurement.

MENU **TRIGGER MENU** **SINGLE**

6. Rotate the RPG knob, and move the marker to the measurement result at 1 MHz. Record the results on the Performance Test Record.

4.4 Performance Test

7. Rotate the RPG knob, and move the marker according to the following table. Then record the results on the Performance Test Record, and use the equation given on the Performance Test Record to calculate the test results.

Test Frequency
10 Hz
100 Hz
1 kHz
10 kHz
100 kHz
10 MHz
100 MHz

Performance Test Record

HP 41802A 1 M Ω Input Adapter

Date: _____
Temperature: _____
Humidity: _____
Serial No.: _____
Tested by: _____

Gain Accuracy/Flatness Tests

Gain Accuracy (at 1 MHz, 0 dBm)

Minimum Limit	Test Result [a]	Maximum Limit	Measurement Uncertainty
-2.0 dB	_____	+2.0 dB	± 0.48 dB

Flatness (relative to 0 dBm at 1 MHz)

Frequency	Reading [b]	Minimum Limit	Test Result [-a + b]	Maximum Limit	Measurement Uncertainty
10 Hz	_____	-2.8 dB	_____	+2.8 dB	± 0.70 dB
100 Hz	_____	-2.8 dB	_____	+2.8 dB	± 0.70 dB
1 kHz	_____	-2.8 dB	_____	+2.8 dB	± 0.70 dB
10 kHz	_____	-2.8 dB	_____	+2.8 dB	± 0.70 dB
100 kHz	_____	-2.8 dB	_____	+2.8 dB	± 0.70 dB
10 MHz	_____	-2.8 dB	_____	+2.8 dB	± 0.70 dB
100 MHz	_____	-2.8 dB	_____	+2.8 dB	± 0.70 dB

Adjustment

Introduction

This chapter describes the adjustments required to return the HP 41802A to a condition to meet the specifications listed in Figure 1-2, if the HP 41802A failed the performance test, or after it has been repaired. If proper performance cannot be achieved after these adjustments, refer to Chapter 6.

Equipment Required

Table 4-1 lists the equipment required for adjustment.

Preparation

This paragraph provides the information which you should know, and the procedures that you must perform before starting the adjustments.

1. Allow the HP 41802A and the test equipment to warm up and stabilize for at least 30 minutes before you execute the adjustments.
2. Perform the adjustments in an ambient temperature of $23\text{ }^{\circ}\text{C} \pm 5\text{ }^{\circ}\text{C}$.

Gain Adjustment

Description

This adjustment adjust the HP 41802A's gain.

Equipment

Network Analyzer:	HP 8751A
Power Splitter:	HP 11667A
10 dB Attenuator Pad:	HP 8491A Opt. 010
20 dB Attenuator Pad:	HP 8491A Opt. 020
N(m)-N(m) Adapter:	PN 1250-0778
N(m)-BNC(f) Adapter:	PN 1250-0780, 2 ea.
50 Ω Feed through:	HP 10100C
N(m)-N(m) Cable:	HP 11500B
BNC(m)-BNC(m) Cable:	PN 8120-1838

Procedure

1. Remove the bottom plate of the HP 41802A.
2. Connect the equipment as shown in Figure 5-1.

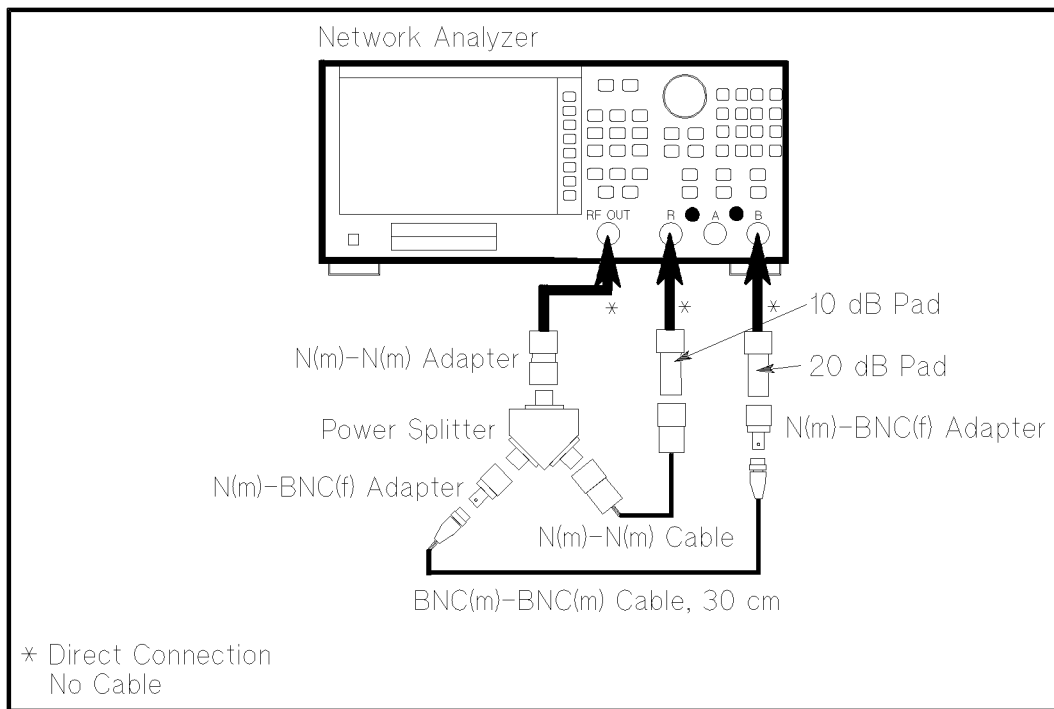

Figure 5-1. Adjustment Setup 1

3. Setup the HP 8751A as follows:

Control Settings	Key Strokes
Preset	[PRESET]
CENTER Freq. = 1 MHz	[CENTER] [1] [M/μ]
SPAN Freq. = 0 Hz	[SPAN] [0] [x1]
Meas. Config: B/R	[MEAS] B/R
Number of Points: 2	[MENU] NUMBER of POINTS [2] [x1]
IF BW = 200 Hz	[AVG] IF BW [2] [0] [0] [x1]
Source Power = +3 dBm	[MENU] POWER [3] [x1]
Marker: Discrete	[MKR] MARKER MODE MENU MARKER DESCRETE
Scale: 0.1 dB/div	[SCALE REF] [] [1] [x1]

4. Perform the following key strokes to do a response calibration.

[CAL] CALIBRATE MENU RESPONSE THRU DONE:RESPONSE

5. Change the connection as shown in Figure 5-2.

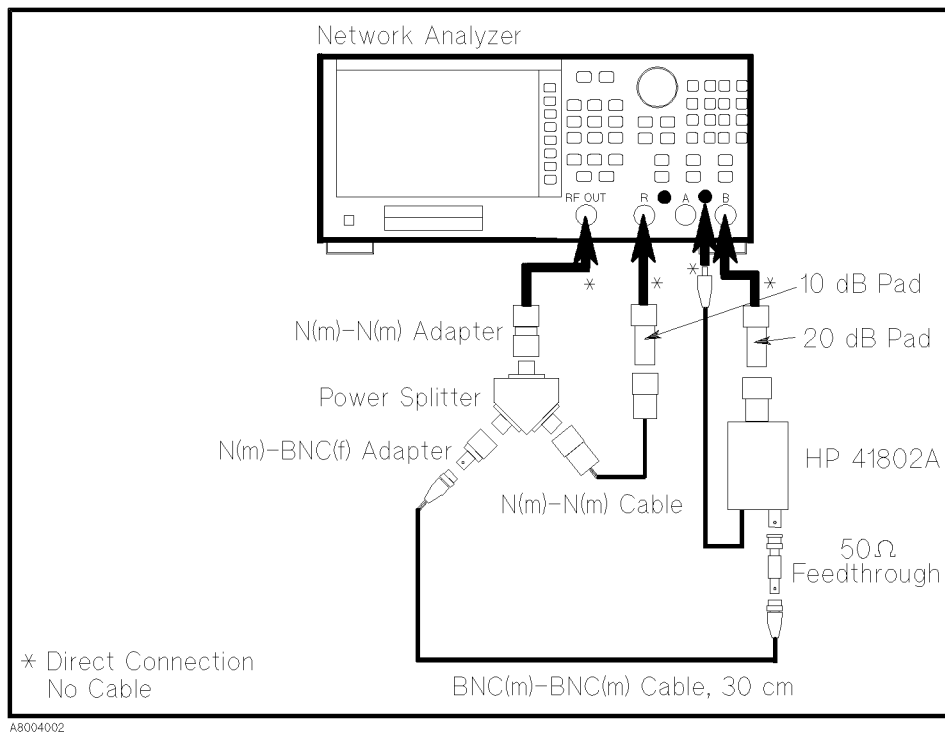

Figure 5-2. Adjustment Setup 2

6. Adjust A1R5 until the marker reading is $0 \text{ dB} \pm 0.1 \text{ dB}$, and is as close as possible to 0 dB.

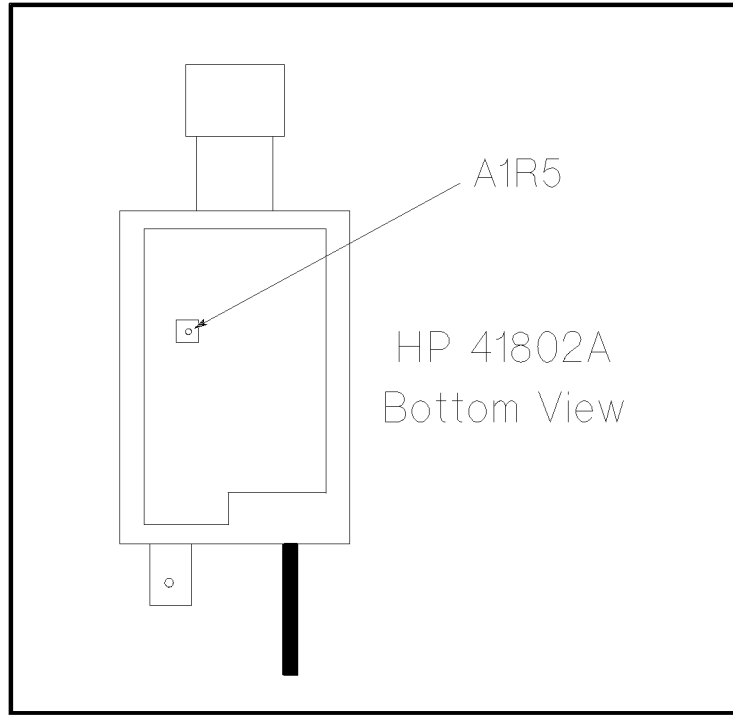

Figure 5-3. Adjustment Setup 3

Replaceable Parts

This chapter provides information about the replaceable parts.

Replaceable Parts Lists

Accompanying each replaceable parts illustration is a replaceable parts list. Each list is arranged in alpha-numerical order by reference designator. The reference designator keys the part listed to the illustration. The first part number listed is HP's part number and may differ from the manufacturer's part number. The check digit serves as an error check of the part number and should be used when ordering a part. Quantity refers to the quantity of the part in the accompanying illustration. The description is a brief written description of the part and may be used for ordering purposes. The manufacturer's code is a five digit number assigned to each manufacturer as listed in Table 6-1. The manufacturer part number may or may not be the same as the HP part number.

Table 6-1. Component Manufactures

Mfr #	Name	Location	Zipcode
28480	HEWLETT-PACKARD CO CORPORATE HQ	PALO ALTO CA US	94304
78189	ILLINOIS TOOL WORKS INC SHAKEPROOF	ELGIN IL US	60126

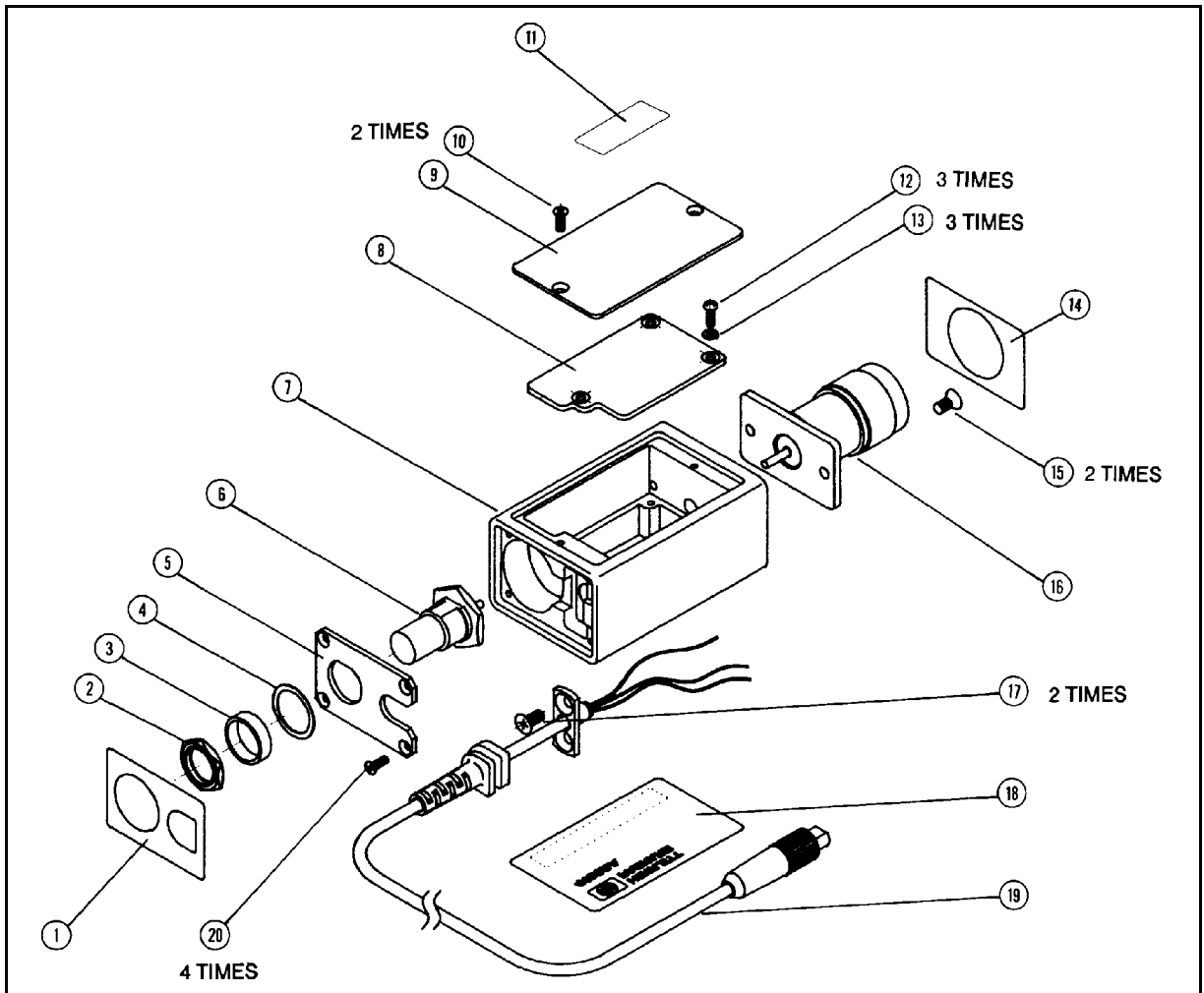

Figure 6-1. Replaceable Parts (1 of 2)

Table 6-2. Replaceable Parts (2 of 2)

RD	Part No.	C D	Qty.	Description	Mfr.	Mfr. Part No.
1	41802-87112	9	1	LABEL	28480	41802-87112
2	2950-0035	8	1	NUT-HEX-DBL-CHAM	28480	2950-0035
3	41802-24003	5	1	SPACER	28480	41802-24003
4	2190-0102	8	1	WSHR-LK INTL T	78189	1922-01
5	41802-07001	7	1	KEEPER	28480	41802-07001
6	1250-1579	2	1	CONN-RF BNC	28480	1250-1579
7	41802-20001	5	1	HOUSING DIVIDER	28480	41802-20001
8	41802-66501	6	1	A1 HI Z ADAPTER	28480	41802-66501
9	41802-04001	1	1	COVER HOUSING	28480	41802-04001
10	0515-1873	0	2	SCREW METRIC	28480	0515-1873
11	5080-3324	2	1	LABEL (Serial No. Plate)	28480	5080-3324
12	0515-0976	2	3	SCR MACH M2X0.4	28480	0515-0976
13	2190-0654	5	3	WASHER LK HLCL 2	28480	2190-0654
14	41802-87113	0	1	LABEL	28480	41802-87113
15	0515-0914	8	2	SCR-MACH M3X0.5	28480	0515-0914
16	1250-2229	1	1	CONN N-PR-237	28480	1250-2229
17	0515-0914	8	2	SCR-MACH M3X0.5	28480	0515-0914
18	41802-87111	8	1	LABEL	28480	41802-87111
19	41802-61601	7	1	CABLE ASSY	28480	41802-61601
20	0515-1873	0	4	SCREW METRIC	28480	0515-1873

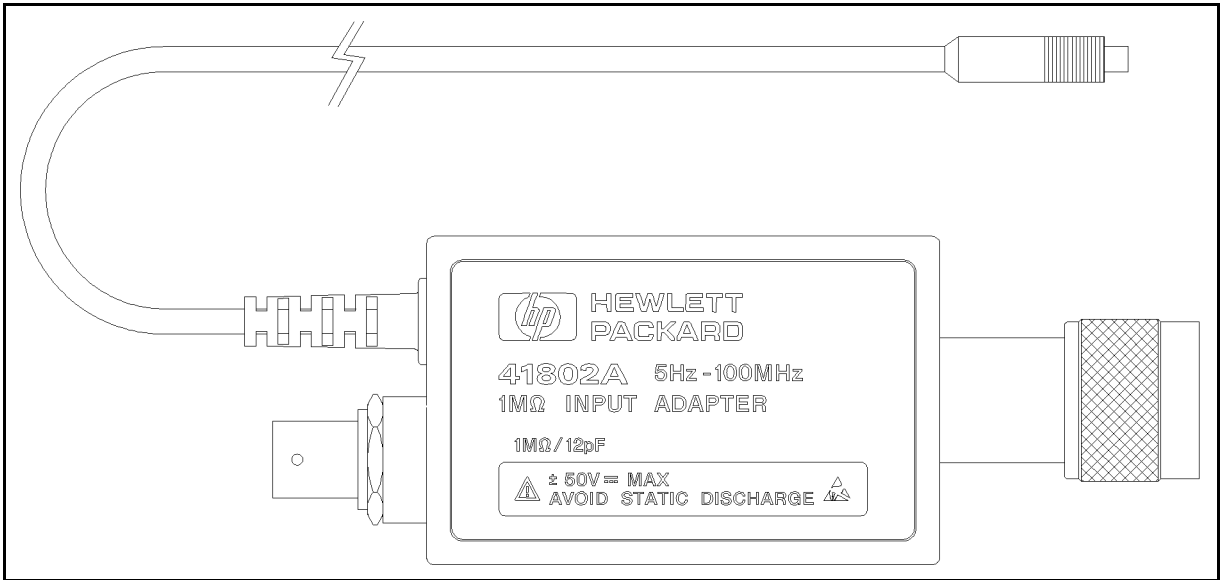

Figure 6-2. Replaceable Parts (2 of 2)

Table 6-3. Replaceable Parts (2 of 2)

RD	Part No.	C D	Qty.	Description	Mfr.	Mfr. Part No.
1	41802-64901	6	1	HI Z ADAPTER (w/o Serial No. Plate)	28480	41802-64901

Manual Changes

Introduction

This appendix contains the information required to adapt this operation note to earlier versions or configurations of the HP 41802A than the current printing date of this manual. The information in this operation note applies directly to HP 41802A whose serial number prefix is listed on the title page of this operation note.

Manual Changes

To adapt this operation note to your HP 41802A, refer to Table A-1, and make all of the manual changes listed opposite your instrument's serial number.

Instruments manufactured after the printing of this manual may be different than those documented in this operation note. Later instrument versions will be documented in a manual changes supplement that will accompany the operation note shipped with that instrument. If your instrument serial number is not listed on the title page of this manual or in Table A-1, it may be documented in a yellow *MANUAL CHANGES* supplement. For additional information on serial number coverage, refer to "Serial Number" in Chapter 1.

Table A-1. Manual Changes by Serial Number

Serial Prefix or Number	Make Manual Changes
	There are no earlier configurations than the printing date of this operation note.

